

## ShipConstructor2004 To Include HVAC

Victoria, May 15, 2003

Slated for release in September 2003: the next major revision of the award-winning 3D product modelling software for shipbuilding and offshore platforms from Albacore Research Ltd. **ShipConstructor2004** will include a full Heating Ventilation and Air-Conditioning module. Northrop Grumman Ship Systems, Avondale Division, will be the first company putting this new module to the test. HVAC was designed from the ground up to be fully integrated with the **ShipConstructor** software suite, making full use of its SQL Server product database. HVAC rounds out the **ShipConstructor** suite of Structure, Pipe, Automatic and Manual Nest, NC Code generation, Outfit, Fairing, and Lofting tools.

### 3D Modelling Environment

Typical of all components in the **ShipConstructor** family, HVAC is a full 3D product modelling module and is expected to drastically reduce drafting errors and time-to-production. Coupled with **ShipConstructor's** powerful and easy-to-use interference checking system, clashes with structure, pipes and other HVAC are easily detected and avoided before going to production. **ShipConstructor** runs as a set of modules within AutoCAD, an environment that many users are already familiar with, allowing new users to hit the ground running with very little training.

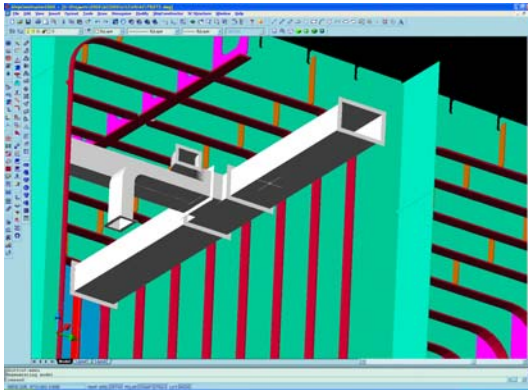

Figure 1: HVAC shown integrated with the Structure module

### Full Featured Reporting

**ShipConstructor's** SQL Server production information database is an integral part of the HVAC module. Every duct is catalogued in the database, along with revisions, to generate

production information and reports. **ShipConstructor's** Manager application makes bills of materials, weights and CGs, and material utilization reports available at the click of a button. HVAC, through its integration with the **ShipConstructor** database and full-featured reporting tools, offers a wealth of valuable information for Planning, Purchasing and Production departments.

### Intelligent Object Technology

With **ShipConstructor**, HVAC ducts are full-featured custom objects within AutoCAD, not just lines and solids. Ducts 'know' how they are connected and what they are connected to; this allows them to be stretched and moved while maintaining their connections in real-time. By developing ducts entities that adapt to changes in the system, ARL has virtually eliminated the need to re-draw large sections of HVAC due to small modifications in the system. This saves design offices time and money. As with all of ARL's intelligent objects, ducts can be exported to regular 3D solids if desired.

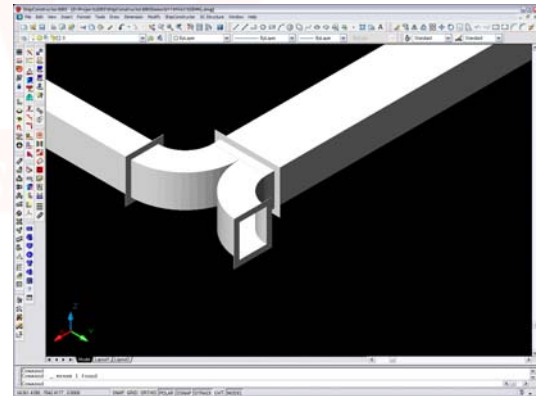

Figure 2: HVAC fully supports both on-the-fly and catalog based modeling

### On-the-fly and Catalog Based modelling

To handle the needs of all customers, HVAC allows both on-the-fly definition of parts and catalogue based modelling. This allows users to easily define ducts for in-house manufacturing, or to specify a library of standard duct parts. Users can make use of a combination of on-the-fly and catalog parts in their drawings, allowing a maximum of flexibility in design.

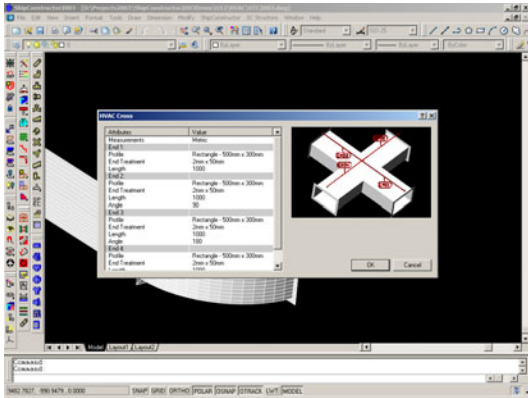

Figure 3: HVAC fully supports both on-the-fly and catalog based modeling

### Additional Features

Planned for inclusion in the HVAC module are tools for specifying vanes and flow direction. Insulation will also be handled with ease for both modelling and interference checking to reduce production errors. And, like **ShipConstructor's** Pipe module, HVAC will fully support spec-driven design, preventing costly mistakes. All of these additional parameters are stored in the SQL Server production database to aid in report generation.

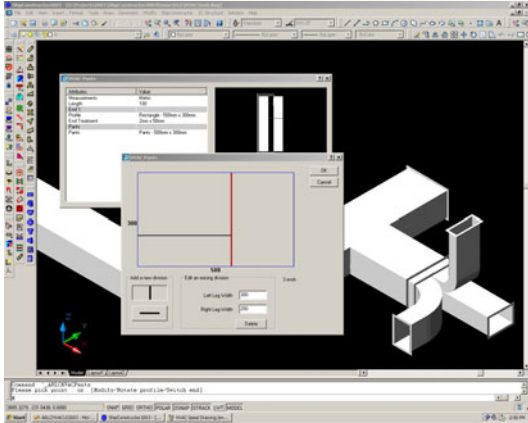

Figure 4: HVAC intelligent 'Pants' or Splitters simplify modeling

### Spool Detail Drawings

Automatic generation of HVAC spool detail drawings is an integrated feature of the new HVAC module. Spool detail drawings are an incredible money-saver for production. Realizing the importance of this time and money-saving tool, the **ShipConstructor** team has developed automatic annotations, bill-of-materials, and weight and CG calculations.

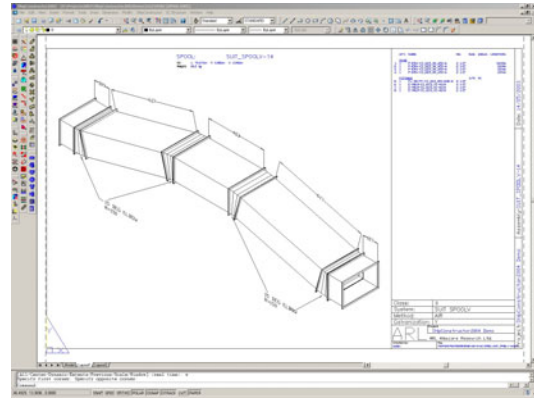

Figure 5: Automatic generated Spool Isometric Drawings

### About Albacore Research Ltd. and ShipConstructor

ARL has grown steadily since it began developing shipbuilding software in 1989. The company quickly established itself as an industry leader with its best-of-breed compound curvature plate expansion program. **ShipConstructor** continues ARL's innovating tradition by integrating with off-the-shelf software to create a detailed product model at a fraction of conventional cost. Over 100 shipyards and naval architects worldwide use ARL software on a wide range of vessels and offshore structure. Recently awarded the Marine Log Award for Enhancing Shipyard Productivity, **ShipConstructor** is recognized as the best design-to-production software tool available for shipyards today.

The **ShipConstructor** platform: fair, loft, model 3D structure, pipes and HVAC, outfit, nest parts and produce NC-code, all within an intuitive and familiar interface. **ShipConstructor** reduces the complexity of shipbuilding by utilizing 3D modelling, interference checking, and industry-specific tools. **ShipConstructor2004** is supported under Windows NT 4, 2000, and XP, running within AutoCAD 2000, 2000i, 2002, or 2004.

For more information, please contact

Mr. Rolf Oetter, President  
**Albacore Research Ltd.**  
#304 – 3960 Quadra Street  
Victoria, BC V8X 4A3  
Canada  
Toll free: 1-888-210-7420  
Tel: 1-250-479-3638  
Fax: 1-250-479-0868  
E-mail: Sales@ShipConstructor.com  
Web: www.ShipConstructor.com